

VER.	AMENDMENT	AUTHORISED BY	DATE

FOR INTERESTS AND NOTIFICATIONS SEE SHEET 2

LIMITED IN DEPTH TO 60.96 METRES

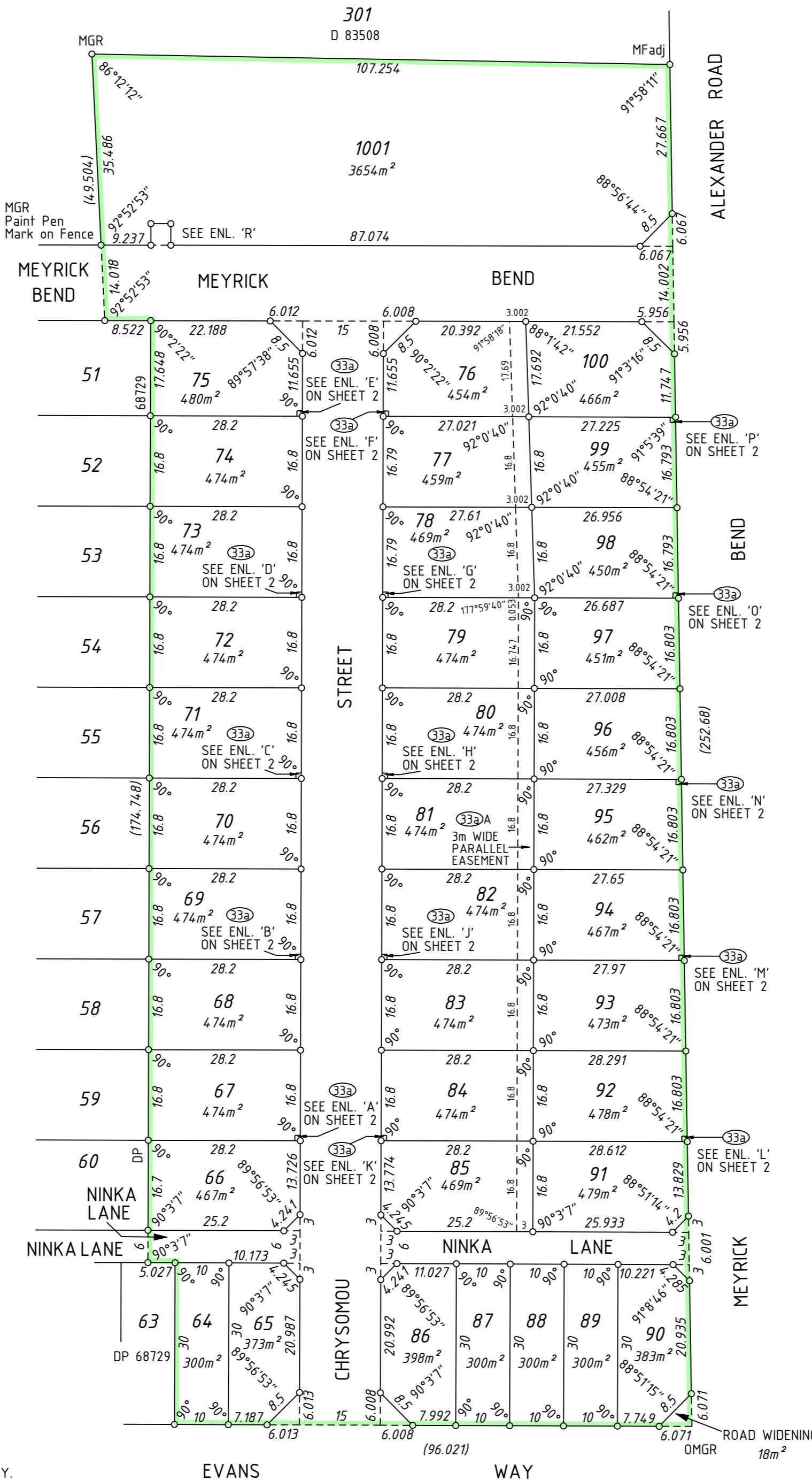
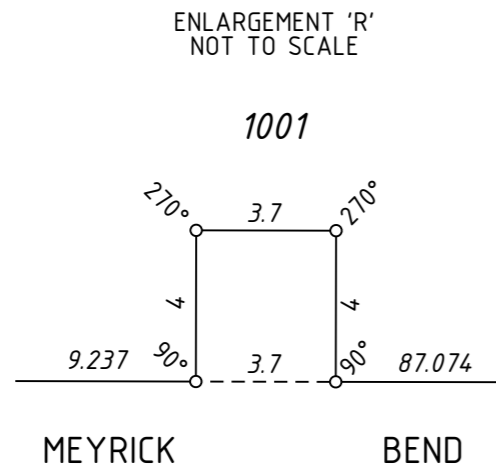

NOTE:  
ALL BOUNDARY / CORNER SURVEY MARKS SHOWN ON THIS SHEET ARE INDICATIVE ONLY.  
USE ONLY THE SURVEY SHEET WHEN DETERMINING THE TRUE FINAL POSITION AND TYPE  
OF ALL SURVEY MARKS PERTAINING TO THIS PLAN.

SURVEY CARRIED OUT UNDER REGULATION 26A SPECIAL SURVEY AREA GUIDELINES  
SEE SHEETS FOR SURVEY INFORMATION.

TYPE FREEHOLD	
PURPOSE SUBDIVISION	
PLAN OF	
LOTS 64-100(inc.), 1001, ROADS ROAD WIDENING, EASEMENTS AND RESTRICTIVE COVENANT	
DISTRICT COCKBURN SOUND (SERPENTINE A.A.)	SSA YES
TOWNSITE	FORMER TENURE
FILE	LOT 9001
LOCAL AUTHORITY SHIRE OF SERPENTINE - JARRAHDALE	DP 68729
LOCALITY BYFORD	VOL FOL
INDEX BG33(2) 22.36	FIELD BOOK 107115
SCALE: 1:750	10 0 10 20 30 40
AT A2 SIZE	
ALL DISTANCES ARE IN METRES	
SURVEYOR'S CERTIFICATE - Reg 54	
I, NEIL BARTLETT, hereby certify that this plan is accurate and is a correct representation of the - (a) * survey; and/or (b) * calculations from measurements, undertaken for the purposes of this plan and that it complies with the relevant written law(s) in relation to which it is lodged. (* delete if applicable)	SURVEYOR'S CERTIFICATE - Compiled I hereby certify that this compiled plan (a) is a correct and accurate representation of the survey(s) of the subject land; and (b) is in accordance with the relevant law in relation to which it is lodged.
Licensed Surveyor Date	Licensed Surveyor Date
SURVEY FIRM	FUGRO SPATIAL SOLUTIONS Pty. Ltd. 18 PROWSE STREET WEST PERTH, W.A., 6005 TEL. (08) 9282 4100 FAX. (08) 9322 1775 MARRI PARK ESTAYE STAGE 2D PLAN No. 62/164603-1 Rev 2
LOGGED	TYPE OF VALIDATION
DATE	FULL AUDIT
FEE PAID	LEGAL COMPONENT
ASSESS No.	DOCKET
	CERTIFIED CORRECT
	I.S.C.
	F.S.C.
	APPROVED BY WESTERN AUSTRALIAN PLANNING COMMISSION
	FILE 136359
	DELEGATED UNDER S16 P & D ACT 2005
	DATE
IN ORDER FOR DEALINGS	
SUBJECT TO	
FOR INSPECTOR OF PLANS & SURVEYS / AUTHORISED LAND OFFICER DATE	
APPROVED REG 26A (4)	
INSPECTOR OF PLANS & SURVEYS / AUTHORISED LAND OFFICER DATE	
 Western Australian Land Information Authority	
DEPOSITED PLAN	
68730	
SHEET 1	OF 2
VERSION 1	

INTERESTS AND NOTIFICATIONS

SUBJECT	PURPOSE	STATUTORY REFERENCE	ORIGIN	LAND BURDENED	BENEFIT TO	COMMENTS
33a	EASEMENT (DRAINAGE)	SECTION 167 OF THE P. AND D. ACT REG. 33(a)	THIS PLAN	LOTS 67, 69, 71, 73, 75, 76, 78, 80, 82, 84, 92, 94, 95, 98, 99	SHIRE OF SERPENTINE-JARRAHDALE	
33aA	EASEMENT (DRAINAGE)	SECTION 167 OF THE P. AND D. ACT REG. 33(a)	THIS PLAN	LOTS 76-85	SHIRE OF SERPENTINE-JARRAHDALE	
	RESTRICTIVE COVENANT	SECTION 136D OF THE T.L.A.	DOC AND THIS PLAN	ALL LOTS EXCEPT 1001	ALL LOTS EXCEPT 1001	
	NOTIFICATION	SECTION 70A OF THE T.L.A.	DOC	LOTS 67, 69, 71, 73, 75, 76, 78, 80, 82, 84, 92, 94, 95, 98, 99		STORMWATER DRAINAGE
	NOTIFICATION	SECTION 70A OF THE T.L.A.	DOC	LOTS 66, 68, 70, 72, 74, 77, 79, 81, 83, 85, 91, 93, 96, 97, 100		STORMWATER DRAINAGE
	MEMORIAL	SECTION 67B OF THE WATER AGENCIES (POWERS) ACT 1984	THIS PLAN	ALL LOTS EXCEPT 9001	WATER CORPORATION	

FOR HEADING SEE SHEET 1

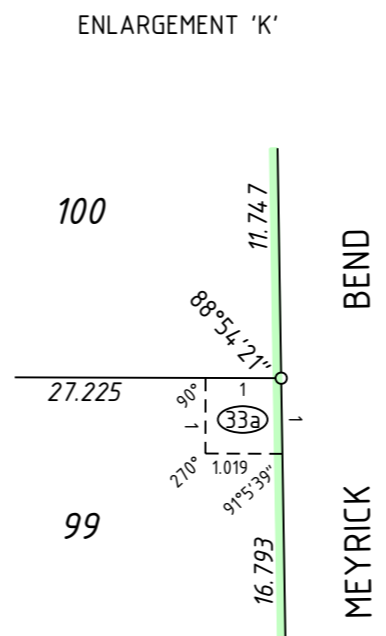
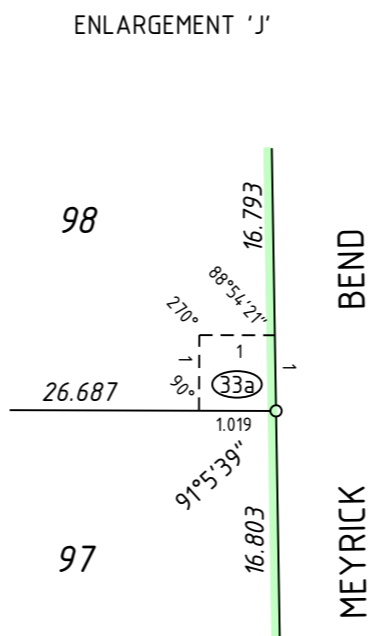
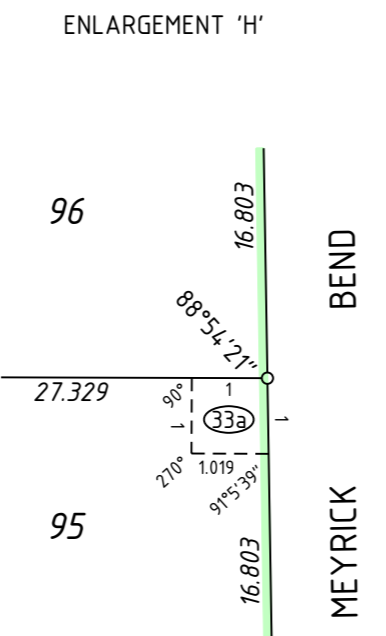
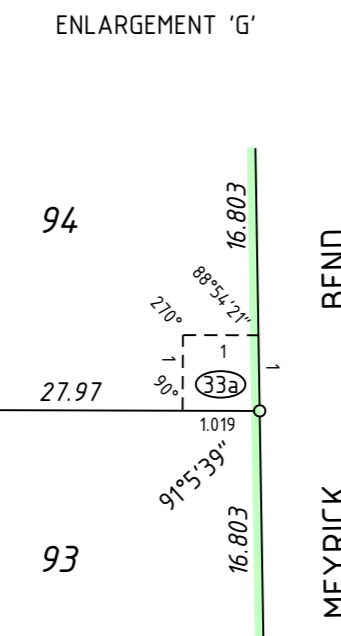
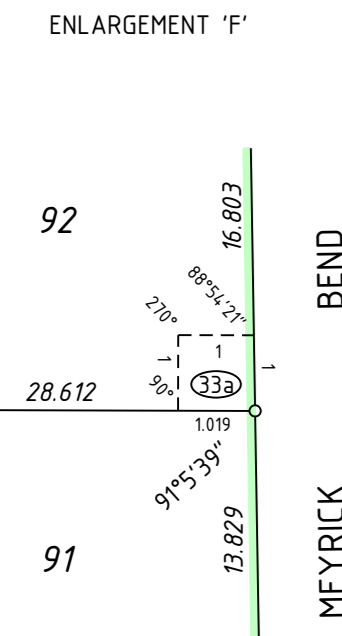
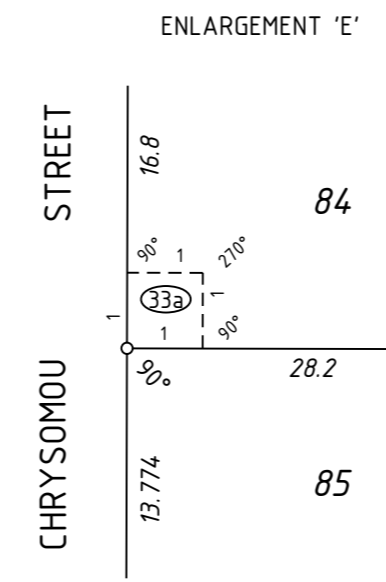
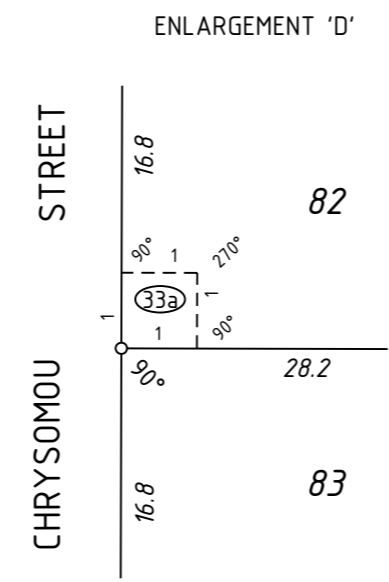
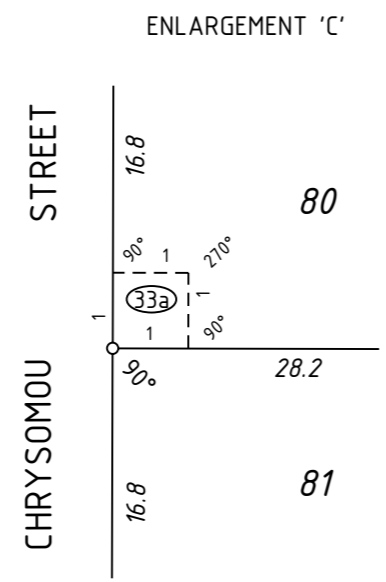
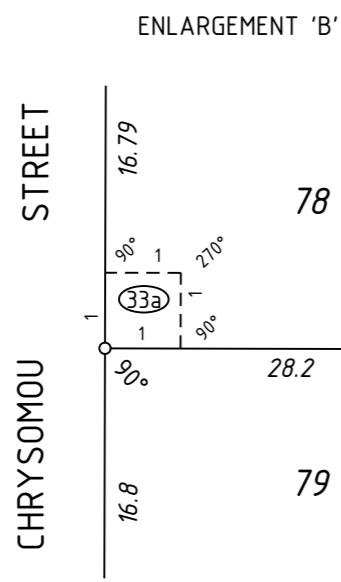
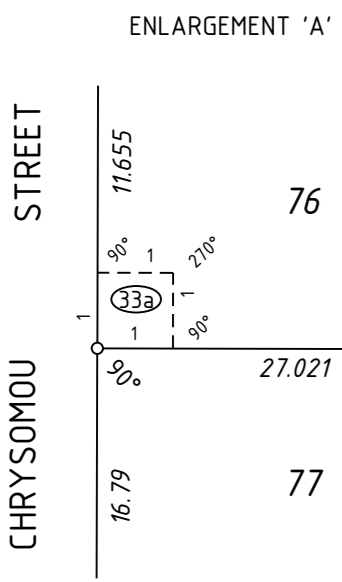
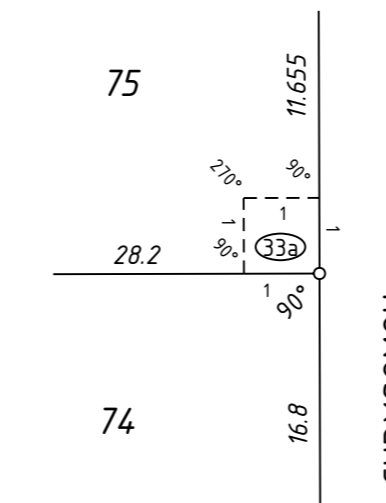
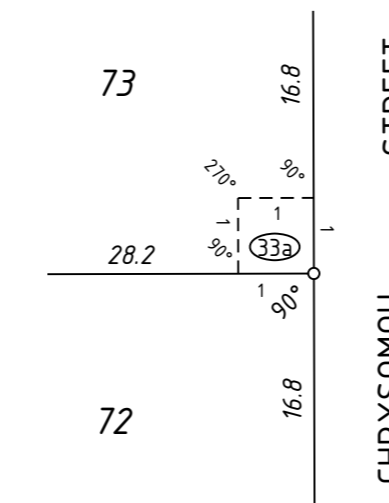
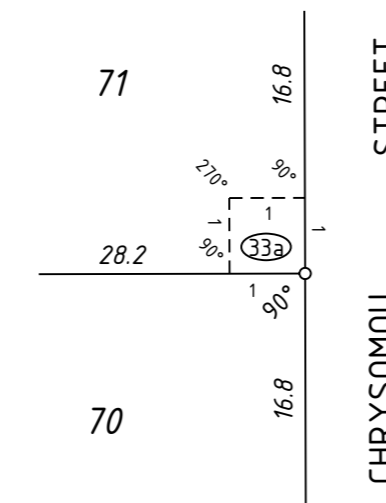
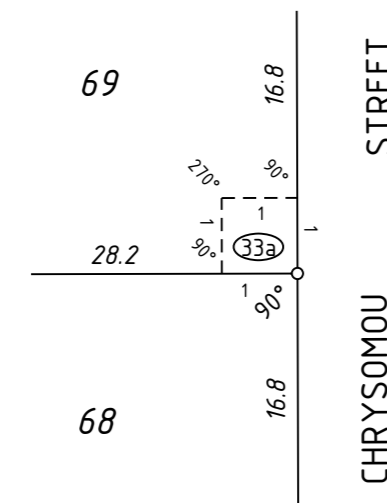
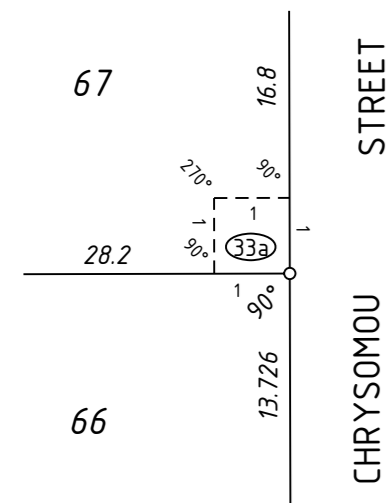

SCALE: 1:100  
AT A2 SIZE  
ALL DISTANCES ARE IN METRES

Licensed Surveyor	Date
FUGRO SPATIAL SOLUTIONS	62/164604-1 Rev: 2
APPROVED BY	
WESTERN AUSTRALIAN PLANNING COMMISSION	
FILE	136359
DELEGATED UNDER S16 P & D ACT 2005	
DATE	
SHEET	2 OF 2
VERSION	1

DEPOSITED PLAN  
**68730**