

AMENDMENTS TABLE (PLAN GRAPHIC ONLY)

INTERESTS AND NOTIFICATIONS

VER.	AMENDMENT	AUTHORISED BY	DATE	SUBJECT	PURPOSE	STATUTORY REFERENCE	ORIGIN	LAND BURDENED	BENEFIT TO	COMMENTS
					MEMORIAL	SECTION 128(2) OF THE WATER SERVICES ACT 2012	THIS PLAN & DOC	LOTS 179-204, 210	WATER CORPORATION	
				(33a)	EASEMENT (DRAINAGE)	SECTION 167 OF THE P & D ACT REG 33(a)	THIS PLAN	LOTS 180, 182, 184, 186, 187, 190, 192, 194, 195, 198, 199, 201, 203, 210	SHIRE OF SERPENTINE-JARRAHDALÉ	
					RESTRICTIVE COVENANT	SECTION 136D OF THE T.L.A.	THIS PLAN & DOC	LOTS 179-204, 210	LOTS 179-204, 210	
					NOTIFICATION	SECTION 165 OF THE P & D ACT 2005	DOC	LOTS 179-204, 210		PROXIMITY TO TROTting COMPLEX

SURVEY CARRIED OUT UNDER REGULATION 26A
SPECIAL SURVEY AREA GUIDELINES
SEE SURVEY SHEET(S) FOR SURVEY INFORMATION



A50666
1000
DP 64927

TYPE	FREEHOLD
PURPOSE	SUBDIVISION
PLAN OF	LOTS 179-204,210, 9005, ROADS, EASEMENT AND RESTRICTIVE COVENANT
DISTRICT	COCKBURN SOUND
TOWNSITE	
FILE	
LOCAL AUTHORITY	SHIRE OF SERPENTINE-JARRAHDALÉ
LOCALITY	BYFORD
ON INDEX	SEE SMARTPLAN
SSA	YES
FORMER TENURE	LOT 9004 DP 400772 C/T 2850-834
FIELD BOOK	100214

SCALE: 1:1500
AT A2 SIZE
ALL DISTANCES ARE IN METRES

SURVEYOR'S CERTIFICATE - Reg 54
NEIL A. BARTLETT
hereby certify that this plan is accurate and is a correct representation of the -
(a) * survey, and/or
(b) * calculations from measurements recorded in the field records.
[* delete if inapplicable]
undertaken for the purposes of this plan and that it complies with the relevant written law(s) in relation to which it is lodged.

SURVEYOR'S CERTIFICATE - Compiled
I hereby certify that this compiled plan (a) is a correct and accurate representation of the survey(s) of the subject land; and (b) is in accordance with the relevant law in relation to which it is lodged.

Licensed Surveyor Date
SURVEY FIRM
FUGRO
FUGRO SPATIAL SOLUTIONS Pty. Ltd.
18 PROWSE STREET
WEST PERTH, W.A., 6005
TEL. (08) 9282 4100
FAX. (08) 9322 1775
LARSEN ROAD BYFORD STAGE 6
PLAN No. 62164609-1 (Rev.0)

LODGED	TYPE OF VALIDATION	APPROVED BY
DATE	FULL AUDIT	WESTERN AUSTRALIAN PLANNING COMMISSION
FEE PAID	LEGAL COMPONENT	FILE 148270
ASSESS No.	DOCKET	DELEGATED UNDER S16 P & D ACT 2005
	CERTIFIED CORRECT	DATE
	I.S.C.	
	F.S.C.	

IN ORDER FOR DEALINGS
SUBJECT TO
FOR INSPECTOR OF PLANS & SURVEYS / AUTHORISED LAND OFFICER DATE

APPROVED REG. 26A(4)
INSPECTOR OF PLANS & SURVEYS / AUTHORISED LAND OFFICER DATE



DEPOSITED PLAN
403852
SHEET 1 OF 3
(PLUS SURVEY SHEET(S))
VERSION 1

FOR HEADING SEE SHEET 1
 FOR INTERESTS AND NOTIFICATIONS SEE SHEET 1

A50666
 1000
 DP 64927

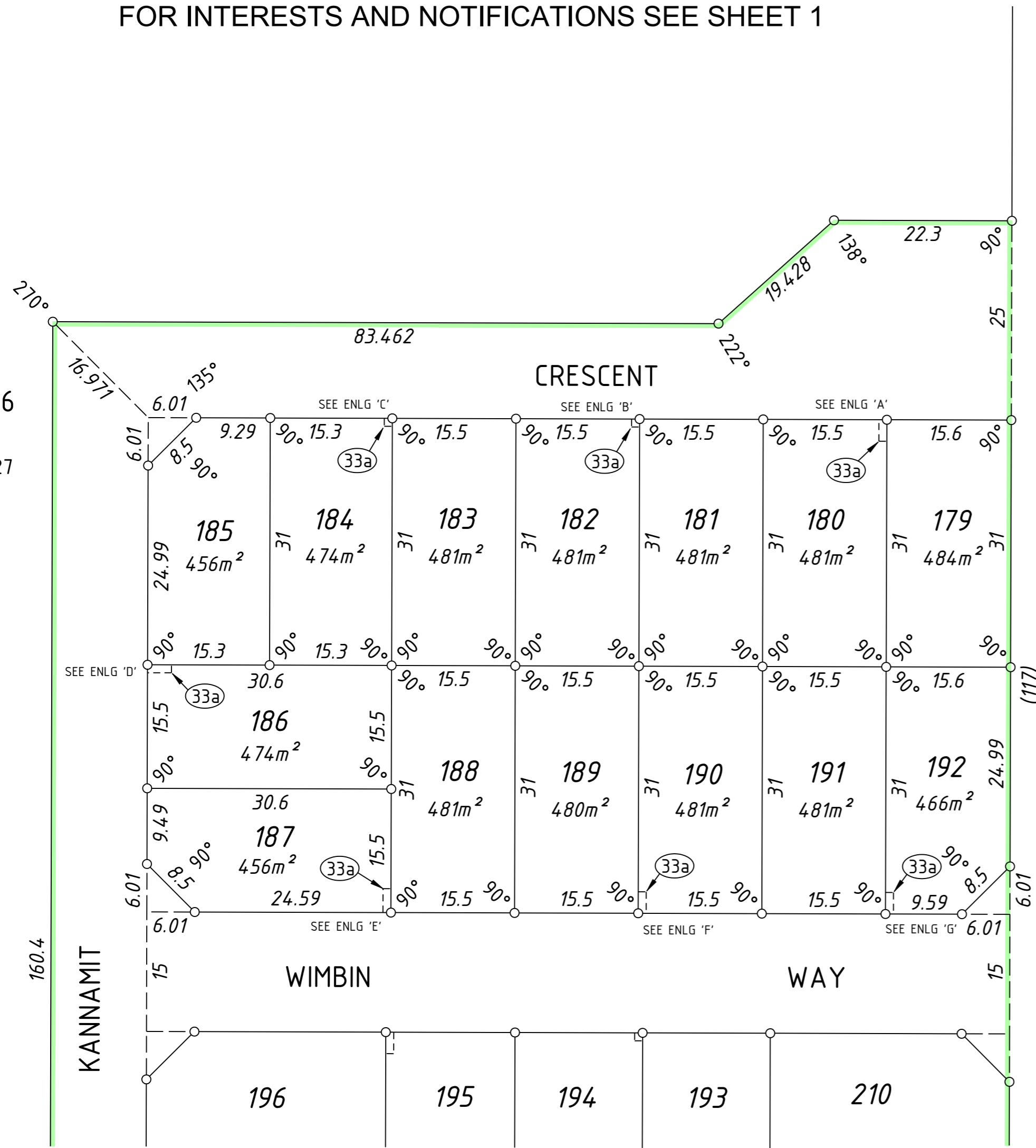

KANNAMIT CRESCENT

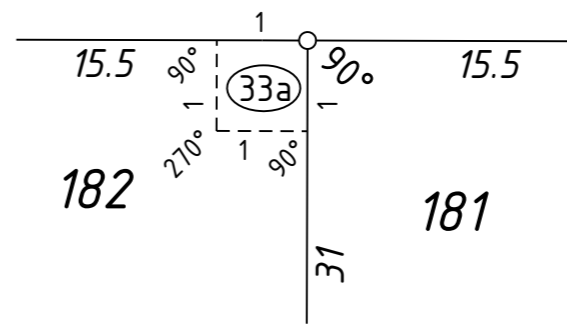

ENLARGEMENT 'B'
 NOT TO SCALE

KANNAMIT CRESCENT

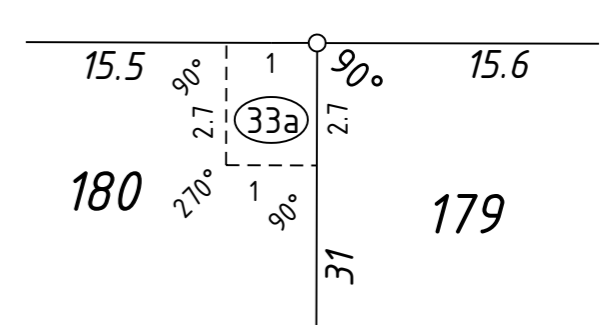

ENLARGEMENT 'A'
 NOT TO SCALE

KANNAMIT CRESCENT

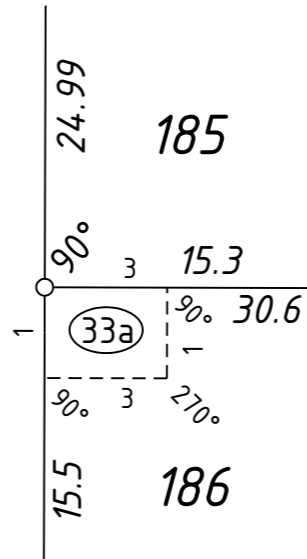

ENLARGEMENT 'D'
 NOT TO SCALE

KANNAMIT CRESCENT

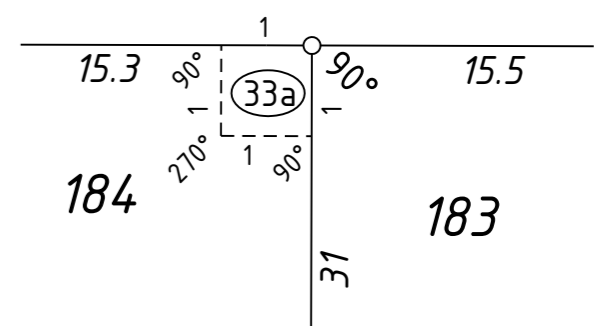

ENLARGEMENT 'C'
 NOT TO SCALE

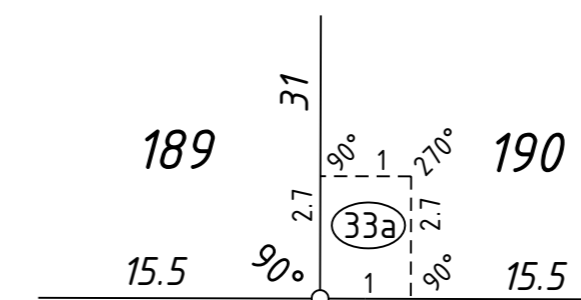

WIMBIN WAY

ENLARGEMENT 'F'
 NOT TO SCALE

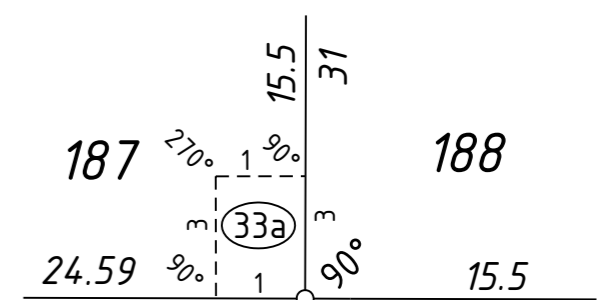

WIMBIN WAY

ENLARGEMENT 'E'
 NOT TO SCALE

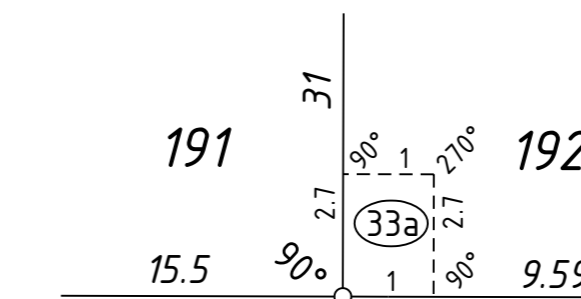

WIMBIN WAY

ENLARGEMENT 'G'
 NOT TO SCALE



SCALE: 1:500
 AT A2 SIZE
 ALL DISTANCES ARE IN METRES

0 5 10 15 20 25m

Licensed Surveyor _____ Date _____

FUGRO
 FUGRO GEOSPATIAL
 PLAN No. 62164609-1 (Rev.0)

Landgate
 Western Australian Land Information Authority

DEPOSITED PLAN
403852

SHEET 2 OF 3
 (PLUS SURVEY SHEET(S))
 VERSION 1

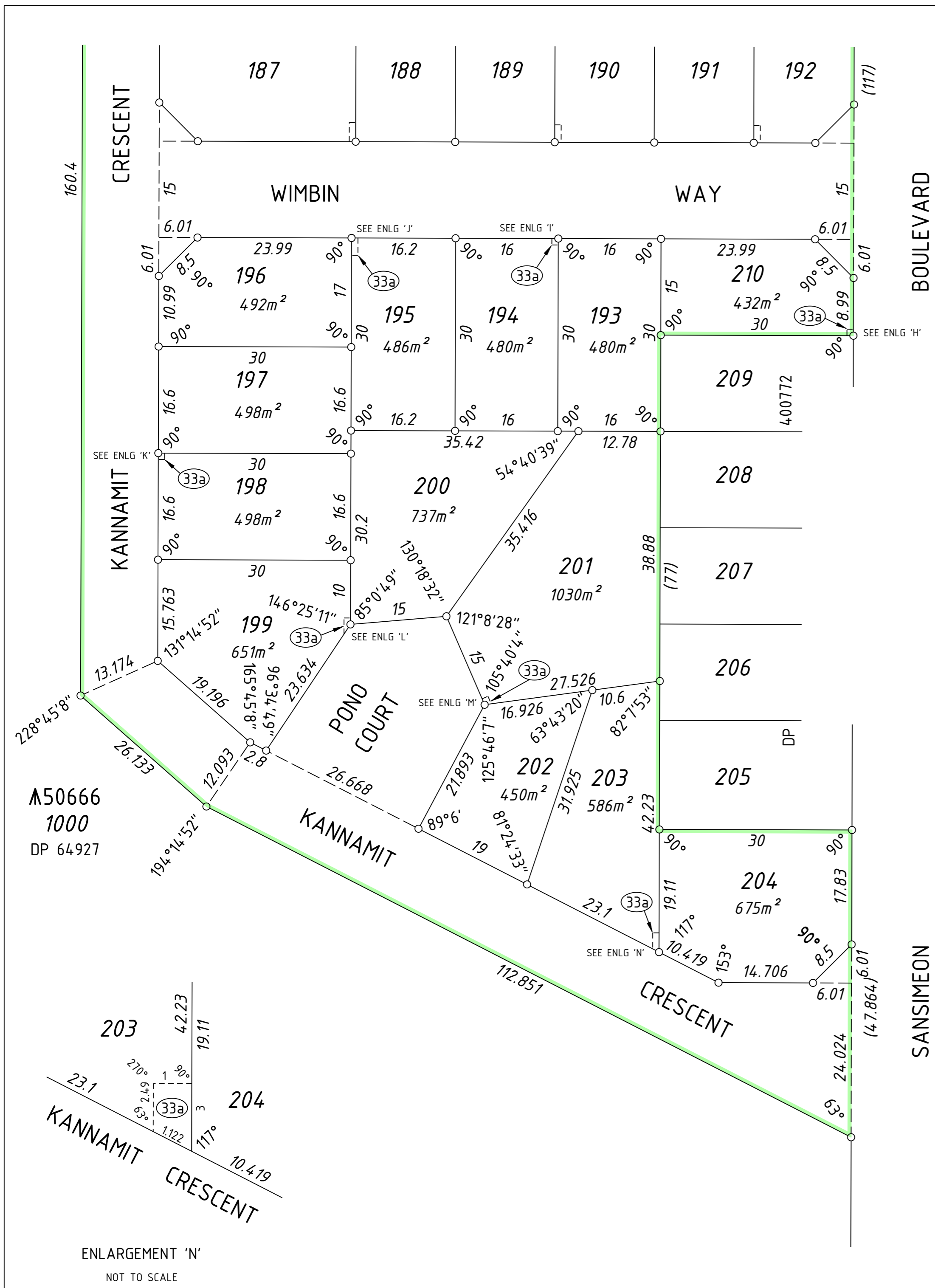

FOR HEADING SEE SHEET 1
FOR INTERESTS AND NOTIFICATIONS SEE SHEET 1

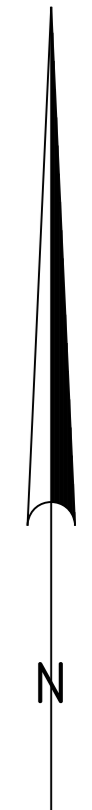
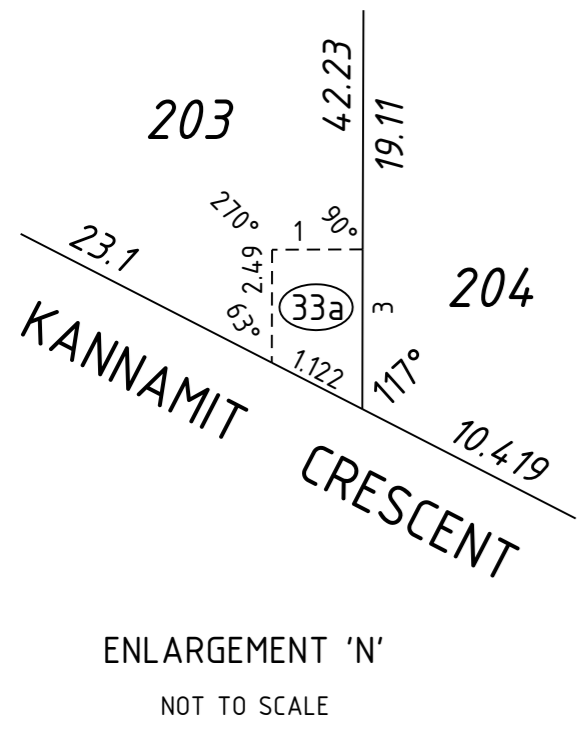
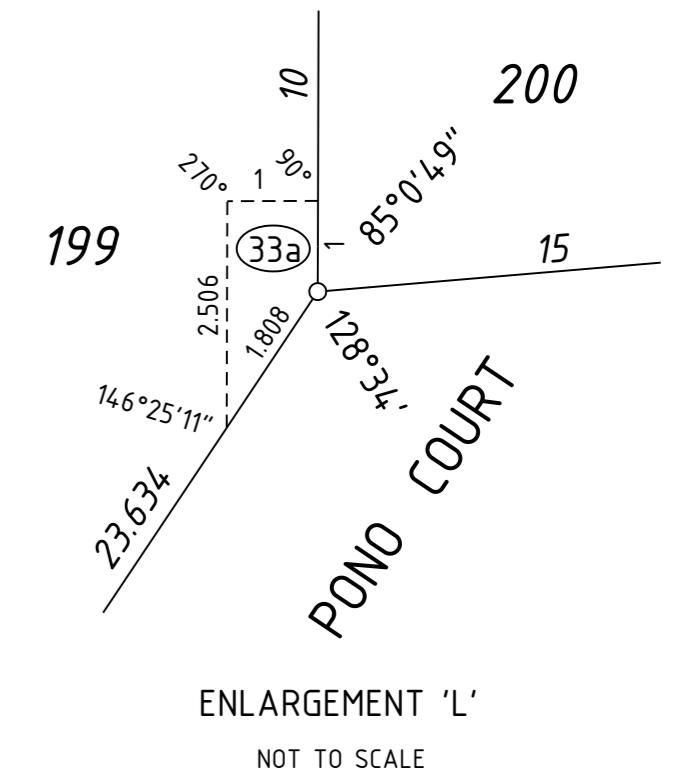
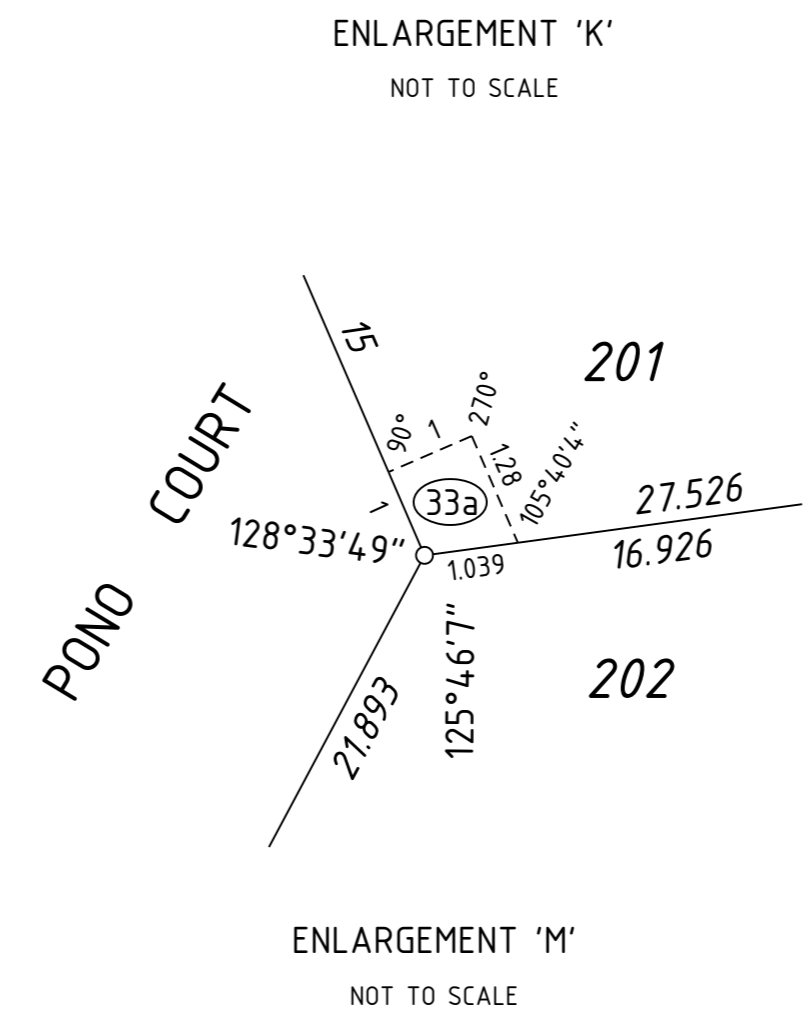
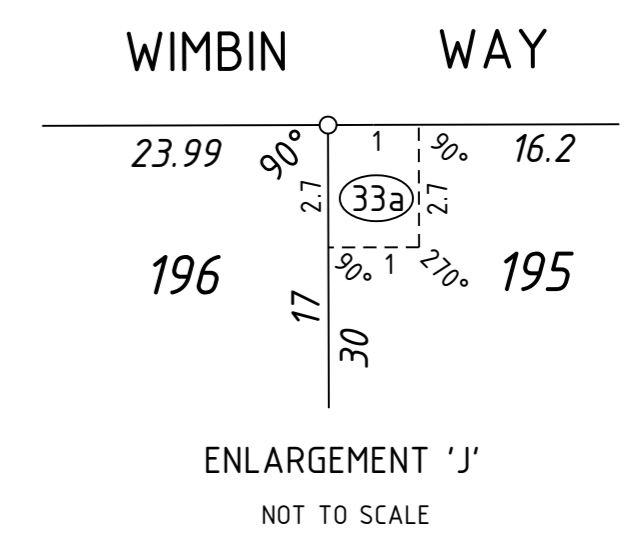
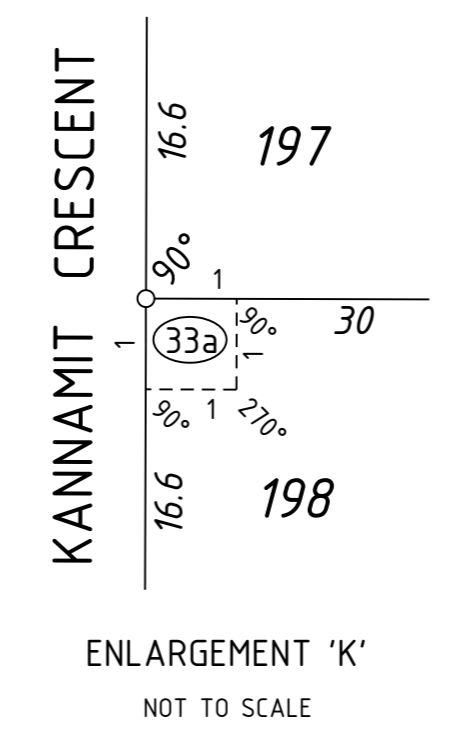
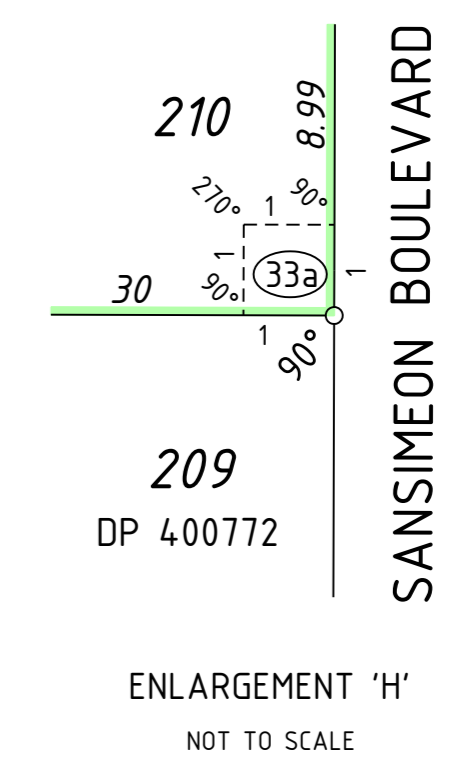
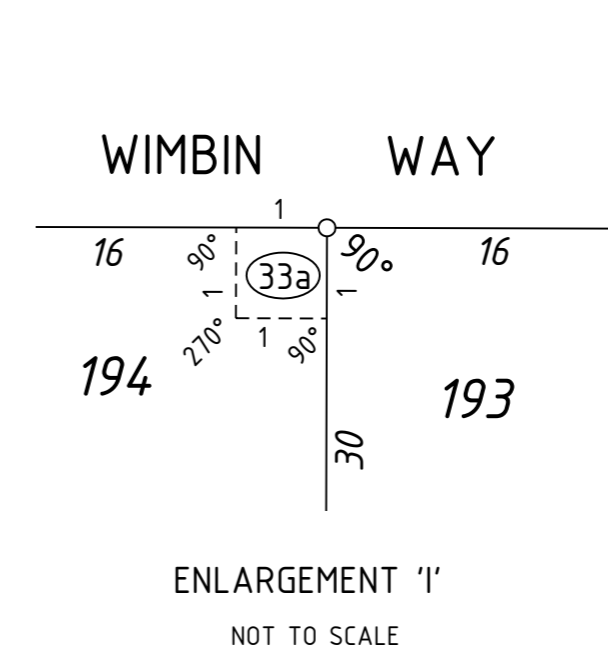

SCALE: 1:500
 AT A2 SIZE
 ALL DISTANCES ARE IN METRES

0 5 10 15 20 25m

Licensed Surveyor _____ Date _____

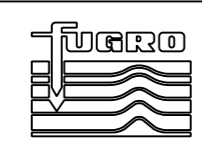
 FUGRO GEOSPATIAL
 PLAN No. 62164609-1 (Rev.0)



Landgate
 Western Australian Land Information Authority

DEPOSITED PLAN
403852

SHEET 3 OF 3
 (PLUS SURVEY SHEET(S))
 VERSION 1

**THIS SURVEY SHEET WILL BE
REPLACED BY THE SURVEY DATA**

SURVEY CARRIED OUT UNDER REG 26A
SPECIAL SURVEY AREA GUIDELINES

SCALE: AT A2 SIZE ALL DISTANCES ARE IN METRES	
Licensed Surveyor	Date
 FUGRO GEOSPATIAL PLAN No. 62164609-1 (Rev.0)	 Landgate Western Australian Land Information Authority
SURVEY SHEET	DEPOSITED PLAN 403852